



David Round, Inc.  
Ruger Division  
32405 Aurora Road  
Solon, OH 44139  
Phone: 440-248-4700  
Fax: 440-248-8544  
www.rugerindustries.com

**RELIABLE**

**HIGHER LIFT**

**HEAVY-DUTY**

**For detailed  
model  
specifications,  
consult a Ruger  
representative**

**440-248-4700**

## 1500 lb MANUAL PUSH LIFT TRUCK

NINE STANDARD MODELS DESIGNED TO LIFT FROM 50" to 150"

### Standard features on ALL units:

- Frame, mast and legs are a solid weldment.
- Shaft mounted type forks permits fine adjustment in fork width.
- Shaft mounted design permits easy removal of forks. Add attachments quickly.
- Roller bearing phenolic resin wheels and ball bearing swivel casters for easier rolling.
- Two leaf-type lifting chains with dual pulleys for maximum durability and reliability.
- Foot parking brake-rubber foot for maximum holding pressure.
- Plexiglass shield for added safety.
- Versatile handle design permits easy pushing or pulling of unit.
- Hydraulic overload relief set at about 10% above normal rated capacity.
- Includes two, six volt three cell, lead-acid batteries rated at 225 amp/hours at a 20 hour rate
- On board 12 volt, 25 amp automatic battery charger ,110 VAC, 3 amp input
- Large hinged access door protects all components.
- Push button control for lifting and lowering.

### OPTIONAL ACCESSORIES/FEATURES:

- AC powered for lifting. Includes appropriate controls and chord with 3 prong grounded plug for insertion into standard 110VAC, 15 amp receptacle.
- Compressed air power - replaces DC system on powered lift models. Includes air motor to drive pump; pressure regulator; air filter, moisture collector and oiler for lubrication.
- Steel & polyurethane wheels.
- Steel platform attachments in various configurations.
- Boom attachments, pole attachments, and attachments for drums.
- Remote control pendant.
- Key lock-mounted on upper control panel.
- Hour meter - accumulates working time.
- Battery fuel gauge.
- Sealed maintenance free batteries and charger.

(Additional accessories listed on reverse side)

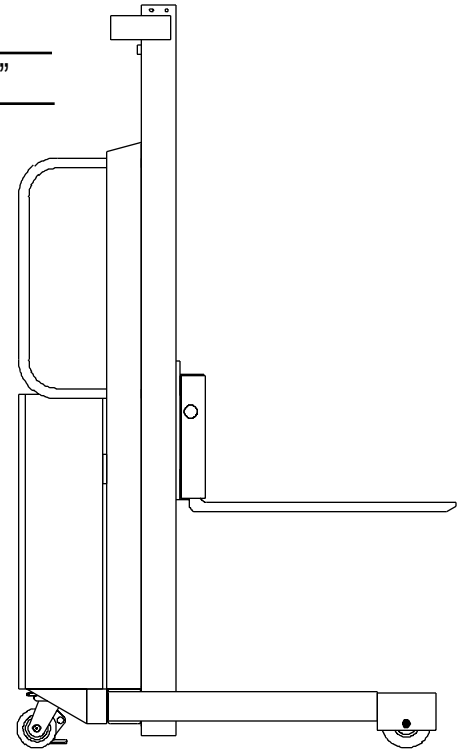

The unique features of the 1500 series are a 20" load center with lifting forks 1" thick x 4" wide and 26" long. The forks descend flat to the floor between the legs. The telescopic models offer full free lift and permit the forks to raise through more than 1/2 of maximum lift before inside mast section extends.

Prices, Specifications, and Options are subject to Change Without Notice.

All Ruger products are shipped F.O.B. Solon, Ohio 44139  
Unit Ships-NMFC #189240 - Class 85

**FAX: 440-248-8544**

**E-mail: [lift@rugerindustries.com](mailto:lift@rugerindustries.com)**



David Round, Inc.  
 Ruger Division  
 32405 Aurora Road  
 Solon, OH 44139  
 Phone: 440-248-4700  
 Fax: 440-248-8544  
 www.rugerindustries.com

**ADJUSTABLE**

**RELIABLE**

**HIGHER LIFT**

**HEAVY-DUTY**

1500 pound -  
 Manual Push/  
 Manual Lift

**DIMENSIONS and PERFORMANCE DATA Load Boosters**

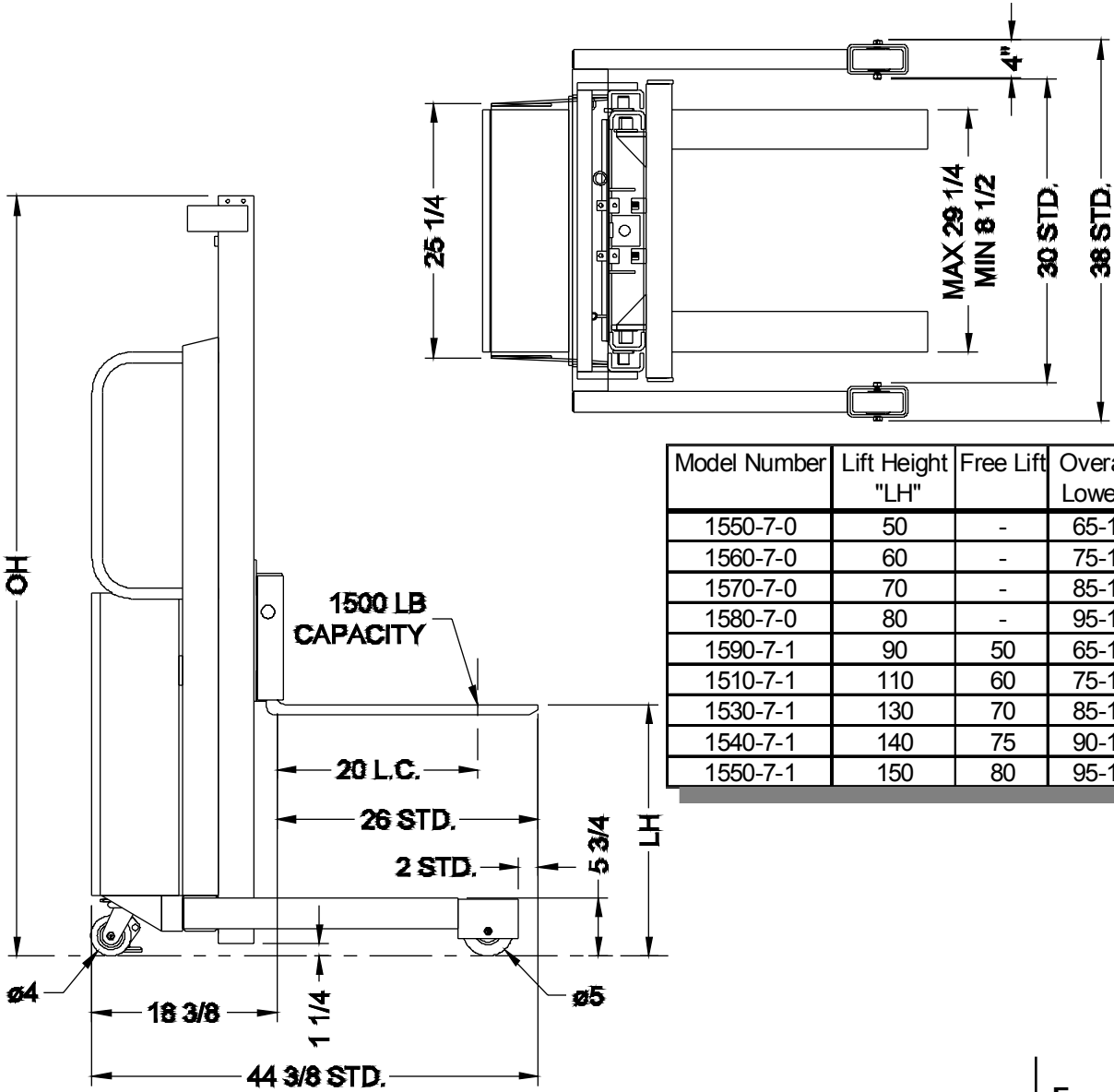

Model Number	Lift Height "LH"	Free Lift	Overall Height "OH"	
			Lowered	Raised
1550-7-0	50	-	65-1/2	-
1560-7-0	60	-	75-1/2	-
1570-7-0	70	-	85-1/2	-
1580-7-0	80	-	95-1/2	-
1590-7-1	90	50	65-1/2	105-1/2
1510-7-1	110	60	75-1/2	125-1/2
1530-7-1	130	70	85-1/2	145-1/2
1540-7-1	140	75	90-1/2	155-1/2
1550-7-1	150	80	95-1/2	165-1/2

**ADDITIONAL OPTIONAL FEATURES**

- Wider straddle width - fixed legs - 30" between legs is standard. Any other dimension from 31" through 50" may be specified. Narrow width legs are also available.
- Adjustable straddle width, adjusts from 34" to 50".
- Longer forks and legs - 36", 42", and 48" length forks are available.
- Low profile legs - 3 1/2" high. (Standard height is 5 3/4")
- Additional lift height for special applications.

**For detailed model specifications, consult a Ruger representative**

**440-248-4700**

NOTE: Models cannot be returned or exchanged when ordered and equipped with optional features.