

# RUGER MODEL: HP1000

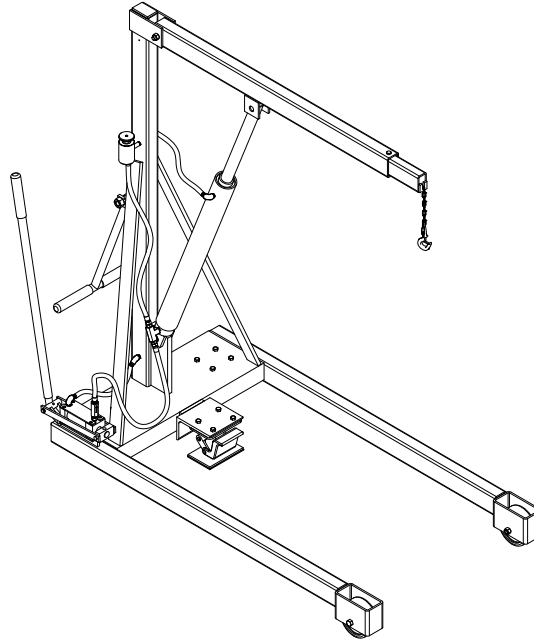

## HP1000

### Standard Features:

- 1,000 lbs maximum rated capacity
- Straddle leg design eliminates the need for counterweights
- Meets Ruger's structural engineering standards for 150% rated lifting capacity
- Meets ASME PALD standards for shop cranes, conforms to ANSI Z535 standards
- Manual hydraulic pump
- Built-in hydraulic pressure relief valve
- Needle release valve permits pin-point load control
- Manual adjustable telescopic boom
- Phenolic resin wheels
- Alloy chain and swivel hook with safety latch
- Steel construction and standard Ruger blue paint

### Optional Accessories:

- Bolt on floor lock kit
- Steel wheels
- Polyurethane wheels
- Bolt on 12V DC powered hydraulic power pack with onboard charger
- Swivel mast & boom – Limited swing angle
- Custom engineered manual winch rated for lifting
- Custom engineered stainless steel construction

The David Round Company, Inc. - Ruger Division - 10200 Wellman Rd - Streetsboro, OH 44241

Phone: 330-656-1600 - Fax: 330-656-1601 - [info@davidround.com](mailto:info@davidround.com) - [www.rugerindustries.com](http://www.rugerindustries.com)

Prices, specifications, and options are subject to change without notice. All Ruger products are shipped F.O.B. Streetsboro, OH 44241

# RUGER MODEL: HP1000



Engineered Handling Solutions Since 1869



*Designers & Manufacturers of Hydraulic Load Lifting and Material Handling Equipment*

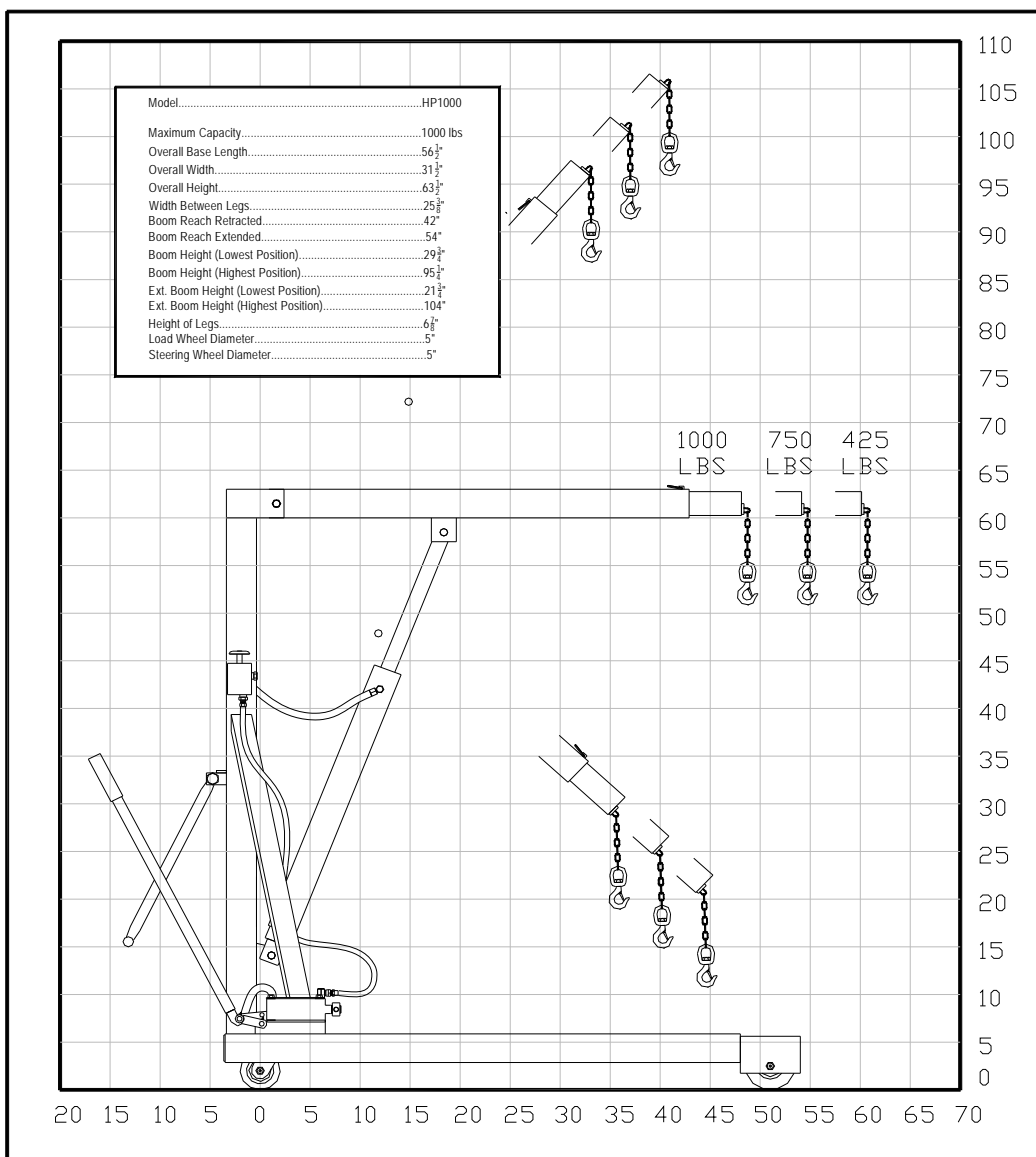

The David Round Company, Inc. - Ruger Division - 10200 Wellman Rd - Streetsboro, OH 44241  
 Phone: 330-656-1600 - Fax: 330-656-1601 - info@davidround.com - www.rugerindustries.com

Prices, specifications, and options are subject to change without notice. All Ruger products are shipped F.O.B. Streetsboro, OH 44241

Copyright 2011