

David Round, Inc.
Ruger Division
32405 Aurora Road
Solon, OH 44139
Phone: 440-248-4700
Fax: 440-248-8544
www.rugerindustries.com

MO RE REA CH

POW ER FU L

HY DR AUL IC

360° ROTATION

TM-2

- 4000 lb. Capacity
- 360 degree boom rotation

ACCESSORIES

- Barrel Grip
- Truck crane mast complete (less mounting socket, mounting brackets and stabilizer)
- Mounting brackets for installing socket on truck
- Stabilizer only (screw type)
- Extra truck crane wells available for truck or pedestal mountings
- Wireless Remote

STANDARD FEATURES

- Meets Ruger's engineering standards 150% structural overload of maximum rated capacity
- 360 degree boom rotation
- Built-in hydraulic overload relief valve
- Adjustable brake to control rotation
- Needle type release valve permits pin-point control over lowering and holding of heaviest or lightest loads
- Truck crane well
- Mounted on Timken tapered roller bearings for easy rotation under maximum loads
- Swivel hook with safety latch and chain to support heavy loads

Prices, Specifications, and Options are subject to Change Without Notice.

All Ruger products are shipped F.O.B. Solon, Ohio 44139,
Unit Ships-NMFC #189240 - Class 70 Shipping Wt. 725 lbs

FAX: 440-248-8544

E-mail: lift@rugerequipment.com

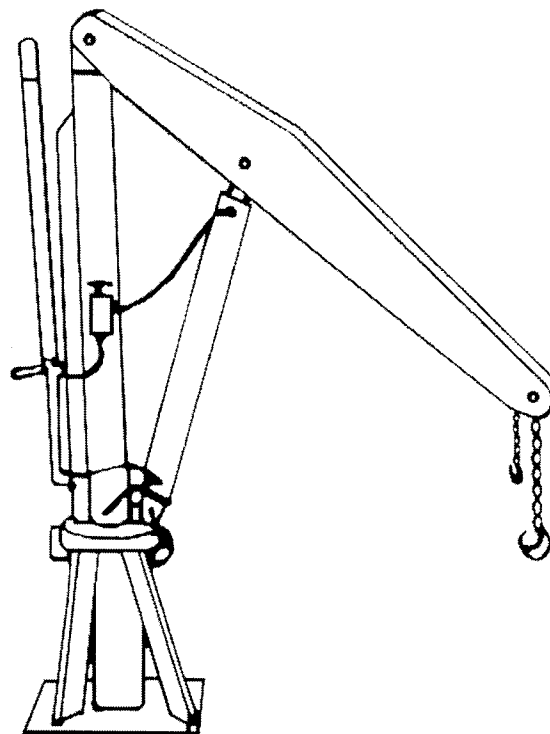

The quality and durability of the TM-2 will follow you everywhere. Tested and exceeds ANSI/ASME PALD-12C standards. Meets ANSI Z.535



David Round, Inc.
 Ruger Division
 32405 Aurora Road
 Solon, OH 44139
 Phone: 440-248-4700
 Fax: 440-248-8544
 www.rugerindustries.com

MO RE REA CH

AFFORDABLE

VE RSA TILE

360° ROTATION

MODEL: TM-2

Model	TM-2
Capacity	4000 lbs
Overall height	63 1/4"
Overall boom length	60"
Boom height (lowest position)	23"
Boom height (highest position)	104"
Mounting floor plate	N/A

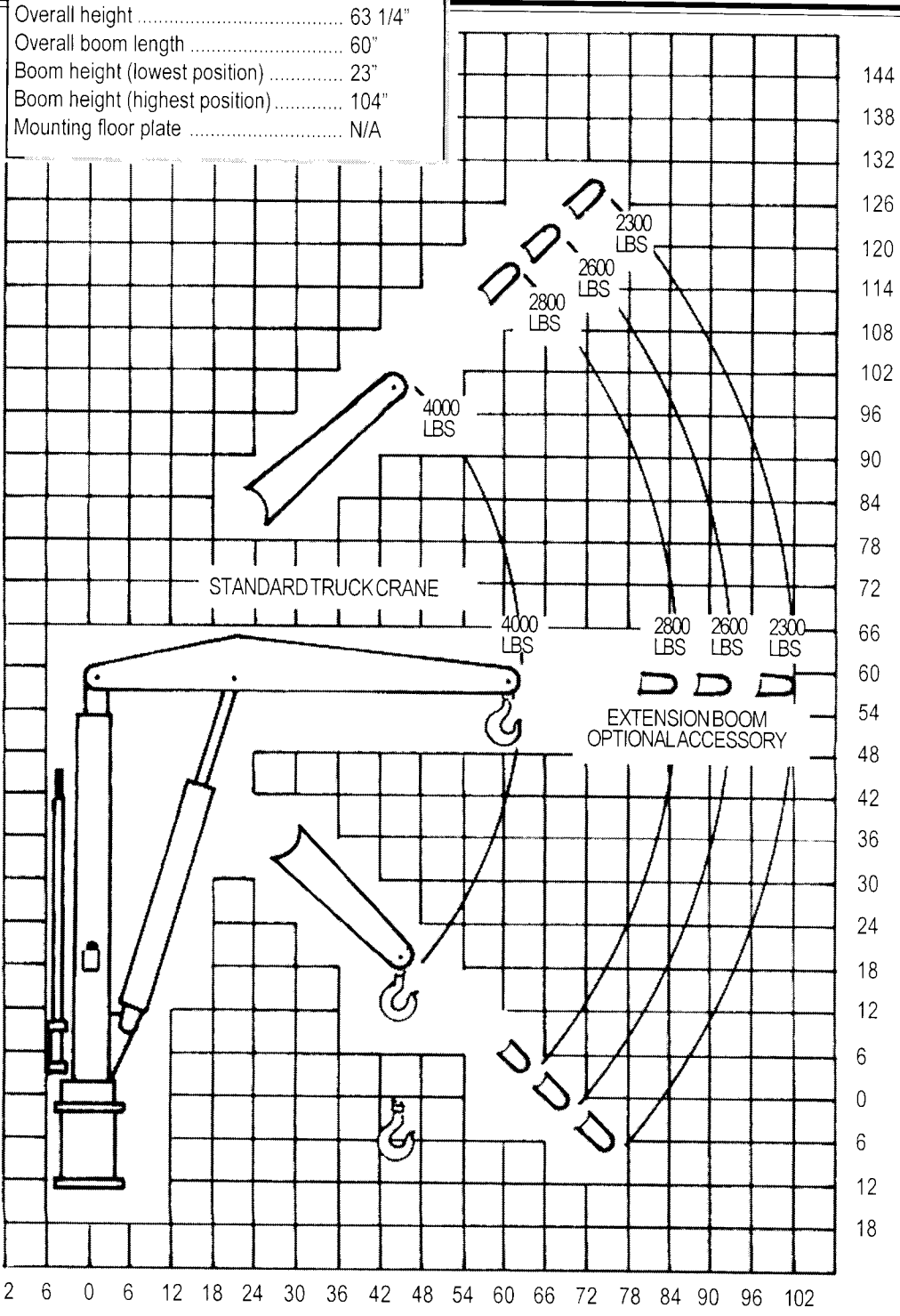

PUMPING CYCLES needed to raise boom through full travel; 35 with crane set for speed and 60 for crane set for power.

Certain models can be shipped NEXT DAY.

NOTE:
 Ruger can modify any standard dimensions to meet specific customer needs.